

# **OPERATION AND INSTALLATION MANUAL**

**Opus Octave**

**70F, 70LS, 70B, 70i, 90i, 90i DS**

**OPUS**

# Table of Contents

Introduction.....	3
1. Delivery.....	3
2. Disposal of packaging.....	3
3. Description.....	3
4. Assembly Instructions.....	4
5. Installation.....	6
i. Basic installation regulations and requirements.....	6
ii. The hearth and floor.....	7
3.3 Minimum distances to combustibles.....	7
iii. Insert casing distance to chamber walls.....	8
iv. Insert chamber ventilation.....	8
v. Heat shielding.....	8
Technical Specification.....	8
6. Combustion air supply.....	9
i. Octave Direct Air Kits.....	9
These allow the stove to be connected to a duct bringing air from outside.....	9
ii. AirSmart.....	11
7. The Chimney.....	12
8. Advice on fitting suitable alarms.....	13
9. Controlling the stove.....	13
10. General information about the working of the stove.....	14
Starting the stove.....	15
11. Cleaning and maintenance.....	16
12. In the case of chimney fire.....	17
13. Suitable materials for lighting.....	17
14. Wood seasoning and storage.....	17
15. Reducing particulate emissions.....	18
16. Emptying the ashpan.....	18
17. Malfunction and service.....	18
18. Troubleshooting.....	19
19. Commissioning checklist.....	20
20. Warranty.....	20
21. Dimensions and parts.....	22
i. 70F, 70LS, 70B.....	22
70i.....	23
90i.....	24
90iDS.....	25

## Introduction

Congratulations on your purchase of this Opus stove.

This manual will introduce you to the functions and correct operation of the stove. It is important that your installer takes you through the operation of this stove during their handover.

Our guarantee is valid only if the guidelines in this manual are carefully followed.

Please keep this manual, in order to remind yourself how to operate the stove before the winter months.

## 1. Delivery

As soon as it is delivered, the stove must be carefully inspected and any damage must be noted on the delivery note. Afterwards the damage must be reported immediately to the retailer.

When transporting the stove you must ensure that only safe, strong and approved carrying methods are used. The stove may only be moved in a stable, standing position or slightly inclined on a sack truck. A sack truck should only be used against the back of the stove. All parts of the stove must be protected against damage, moisture and rain, or other types of contamination during transport and installation.

## 2. Disposal of packaging

The packaging protects the stove from damage during transportation. Any cardboard packaging materials can be recycled. The wooden parts of the packaging are untreated and can be used as firewood.

## 3. Description

The stove is constructed with welded steel. In the centre is the firebox which is lined with firebricks.

Beneath the cast iron grate is an ashpan.

This stove works on the principle of convection, in which cool air is drawn up from the floor and warmed between the two outer walls of the stove. This warm air then spreads around the room.

Inside the combustion chamber you will find:

A box/bag with a thermal glove that allows you to handle the air controls and door and to use when re-fuelling.

A baffle plate (according to the model)

A flue spigot (Octave 70i only)

## 4. Assembly Instructions

Your stove should be installed by a qualified, knowledgeable and experienced installer who is registered under one of the Competent Persons schemes such as HETAS.

The installer must do a thorough check of the appliance to ensure that it is in full working order before it is installed.

**The Octave 70i flue spigot** is supplied separately. This gives the installer an easier installation, especially when the appliance is going to be inserted in a pre-existing fireplace whose height is similar to the height of the appliance.

In order to fit it:

1. Remove
2. Prepare the collar that will be used to fix the flexible liner adaptor to the collar once it is in place.
3. Put a bead of fire cement or high temperature silicone sealant around the collar flange.
4. Screw the collar to the chamber top with the three screws supplied.
5. Make a solid connection between the collar and the flex liner adaptor once the stove is in place.
6. reposition the baffle plate.

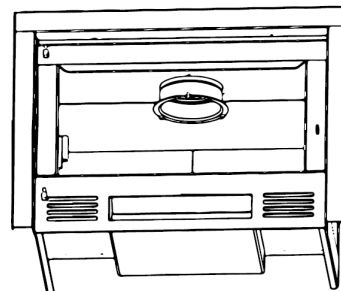
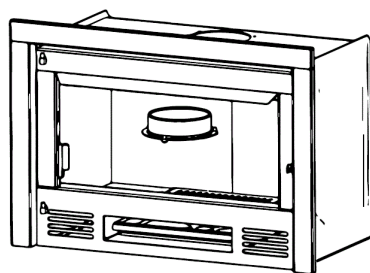

the baffle plate  
the holes on the

**The Baffle plate.** During transport the baffle plate is stored on the base of the firebox. On the Octave 70F, 70 LS, 70B, 70i and 90i the baffle plate is supported on the side and rear firebricks.

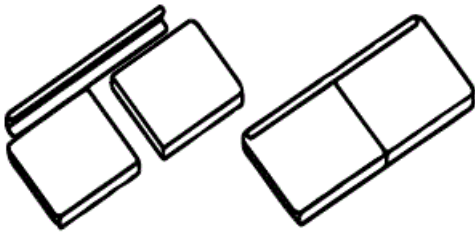

On the Octave 90i DS the baffle plate set consists of the deflector bricks and tertiary combustion tube. The RHS bricks should be positioned first, then insert the RHS end of the baffle set as far as it will go above the

bricks and raise the LHS end. Position the LHS bricks in place and position the baffle set in its correct position on the two sides. Finally insert the screw that ensures the baffle positions itself correctly.

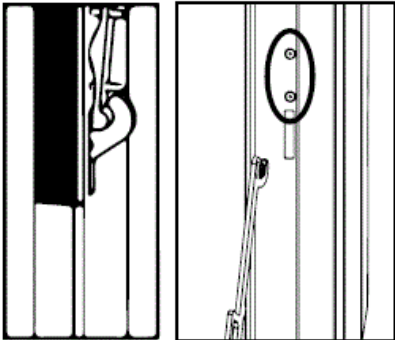
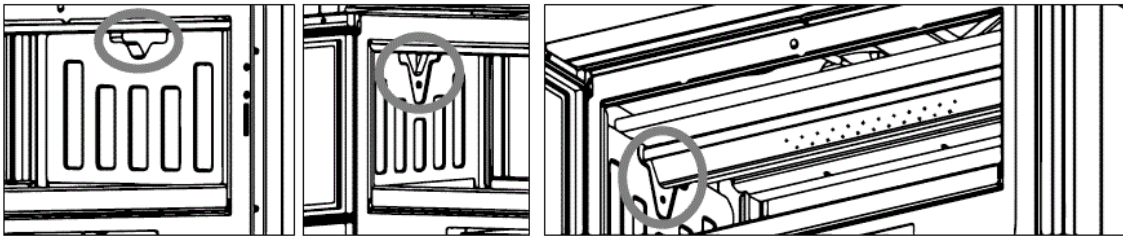

**Door closing adjustment.** On all the Octave models you can adjust the door using the bolts in the front. Tightening or loosening these bolts will ensure the correct adjustment.

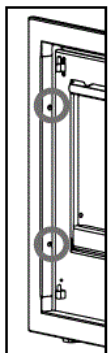

**Insert frame.** All the inserts are supplied with the standard 4 sided frame. To remove the frame:

- i) Remove the door by opening it and moving it upwards.
- ii) Unscrew the two frame bolts on each side of the frame.
- iii) Re-attach the frame once the insert is installed.

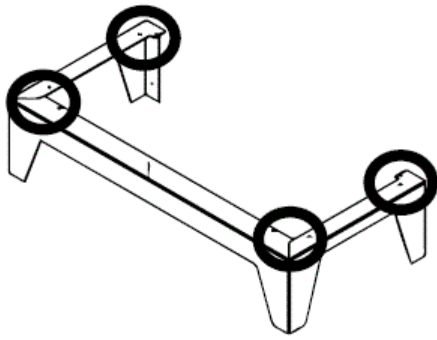

**Octave 70F Stand positioning.** Support the stove over the stand, lining up the six holes in the stove and stand. Bolt the stove and stand together using the six bolts supplied.

**Octave 70LS Log Box positioning.** Support the stove over the log box, lining up the six holes in the stove and log box. Bolt the stove and box together using the six bolts supplied.

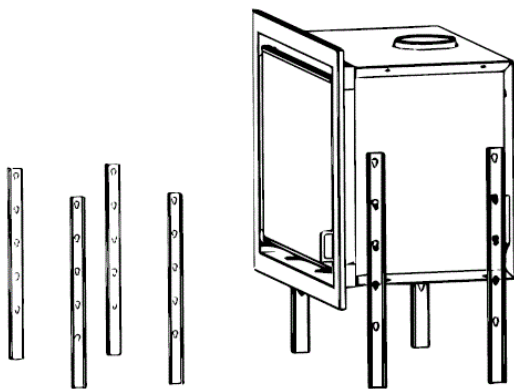
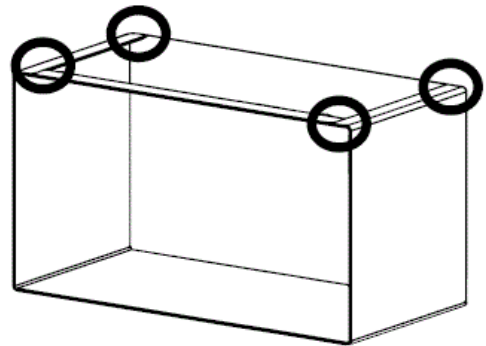

**Adjustable legs installation.** Adjustable legs are available for the Octave 70i and Octave 90i models (this option is not compatible with the Octave 90i DS) to enable the insert to be installed higher up. To fit them you must place the 4 leg holes inside the screws that you will find already screwed on both sides of the insert. You will have the choice of four different heights.

## 5. Installation

### i. Basic installation regulations and requirements

Ventilation systems, such as extractor fans, in the same room as the stove should be avoided where possible, and can adversely affect the function of the stove.

The stove may only be installed in rooms suitable for such an appliance and where it can be operated safely and maintained appropriately and may not be installed in areas in which flammable or explosive substances and mixtures are processed, which could lead to an ignition or explosion.



Throughout the installation the installer must refer to Document J of the Building Regulations for detailed guidance on recommended ways of meeting the building regulation requirements.

## ii. The hearth and floor

Before installing the stove, make sure that the floor on which the appliance is standing has sufficient load capacity. Pay attention to the information on the weight and, if necessary, ensure a sufficient weight distribution by utilising an appropriate hearth.

Floors made of combustible material must be protected by a layer of non-flammable material. This can be done, for example, by tiles or a plate made of glass or sheet metal at least 12mm thick. The floor and hearth must also be strong enough to take the weight of the stove, and be completely level and stable.

Please also observe the necessary measures for the fire protection of the floor. Further details can be found in Building Regulations Document J.



Please also refer to “Firepower Hearth Guidance” which can be found on the [www.firepower.co.uk](http://www.firepower.co.uk) website. This gives recommendations for instances where we recommend that the size of the hearth is increased over and above the minimum sizes given in the building regulations, and also contains some suggestions for how you can make a feature of the hearth.

## 3.3 Minimum distances to combustibles

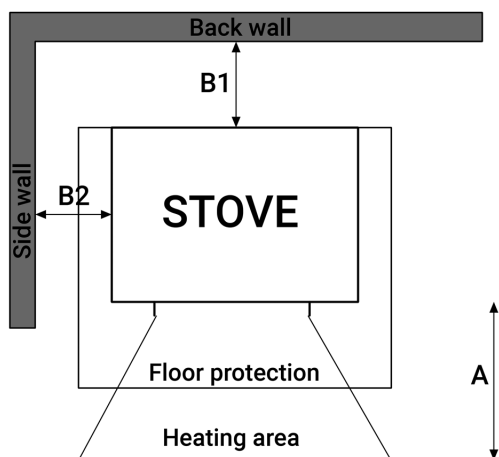

Here are the minimum distances which must be kept between the stove and combustible walls and other combustible materials.

Models

A

B1

B2

Octave 70F, 70LS, 70B, 70i, 90i	1500 mm	400 mm	400 mm
Octave 90i DS	1500 mm	1500 mm	400 mm

### iii. Insert casing distance to chamber walls.

When installing an Octave insert model a gap of at least 8cms should be left between the outer casing of the appliance and the inside wall of the chamber. Side and rear slots in that outer casing should never be blocked.

### iv. Insert chamber ventilation

When installing an Octave insert model you may optionally ventilate the chamber it is installed into at the top and bottom to recover, and spread, more heat to the room. Slot vents are available for this purpose.

### v. Heat shielding

It is also possible to heat shield combustible materials if the stove must be installed at a closer distance than specified here. For heat shielding refer to the guidance detailed below.



For further information on heat-shielding please refer to the “Firepower Heat Shielding Guide” which can be found on the downloads section of the [www.firepower.co.uk](http://www.firepower.co.uk) website.

## Technical Specification

Stove Model	70F/70LS/ 70B	70i	90i	90i DS
Nominal Output (%)	12	12	13	14
Minimum output (%)	3.3	3.3	4.3	
Efficiency (%)	80.7	80.7	81.3	79.5
Weight (kg)	110	91	150	170
Mean flue gas temperature (°C)	307	307	261	231
Flue gas mass flow (g/s)	9.4	9.4	10.6	14.9
Ideal flue pressure (Pa) +/- 2Pa	12	12	12	12
Diameter of flue pipe (mm)	150	150	200	200
Diameter of the external air supply connection (mm)	120	100	100	100
Fuel	Wood	Wood	Wood	Wood
Width, height, depth (mm)	695, 533, 443	695, 533, 443	934, 584, 468	1007, 585, 499



## 6. Combustion air supply

The stove needs sufficient combustion air. This can be drawn from the installation room, which must have a suitable fresh air supply from the outside.

Document J of the Building Regulations provides guidance, including information on the minimum area of ventilation that must be provided to the room. Care and consideration should be given to whether there are any ventilation or extraction systems in the house and when a draught test or smoke spillage test is done these should be switched on so that the “worst case” is tested for. The installer should refer to the HETAS technical notes and guidance on ventilation.

### i. Octave Direct Air Kits.

**These allow the stove to be connected to a duct bringing air from outside.**

**Direct air kit for the Octave 70F, 70LS, 70B** consists of 2 parts; a cover for the front and a collection box for underneath along with the necessary fixings.

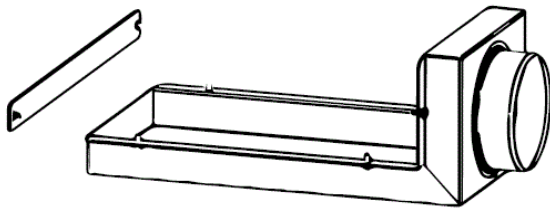

To install the kit:

- i) Remove the knock-out disc on the base of the stove
- ii) Position the collection box under the stove base

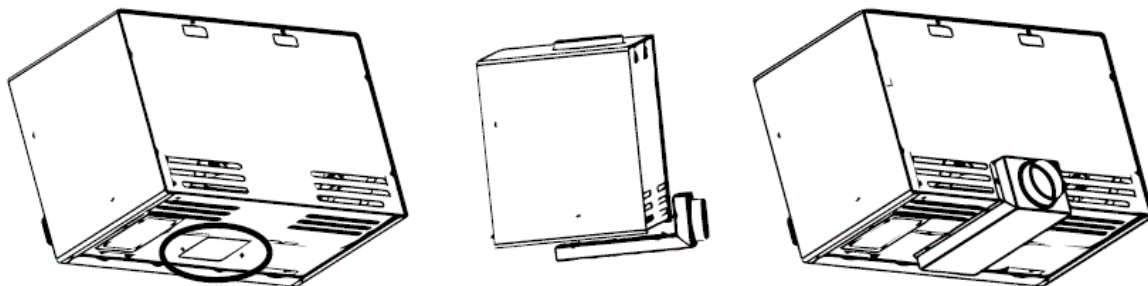

- iii) Using the bolts supplied, connect the box to both the base and the rear of the stove.

iv) Bolt the cover plate to the front of the stove using the bolts supplied to stop it taking air from the room.

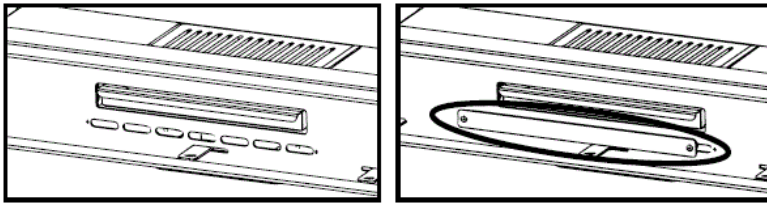

v) The air box spigot can then be connected to a duct with a minimum diameter of 120mm to bring air from outside. Refer to *Firepower direct air guidance document*, details are further down the page.

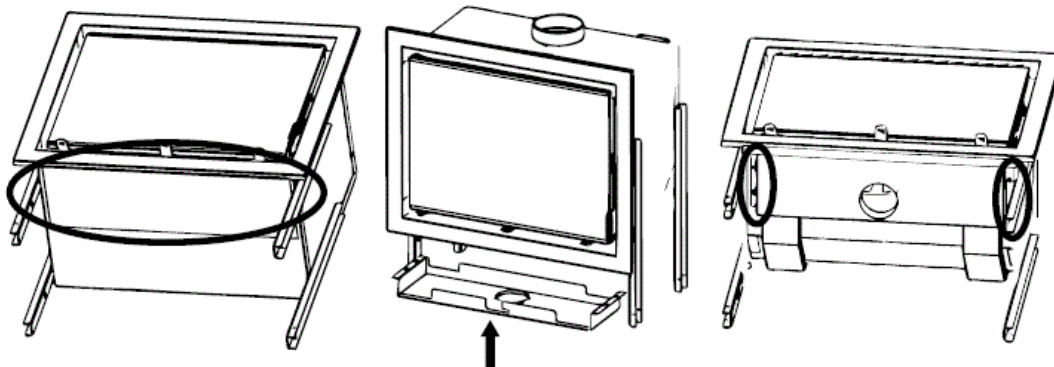

**Direct air kit for Octave 70i and 90i.** This optional kit enables you to bring the combustion air from the outside and will require the stove to be installed with a space underneath. This is best achieved using the adjustable legs kit (see below).

To install the kit remove the knock-out section under the stove and bolt the kit to the base using the bolts supplied. Then connect a duct with a minimum diameter of 100mm to the outside. Refer to *Firepower direct air guidance document*, details are further down the page.

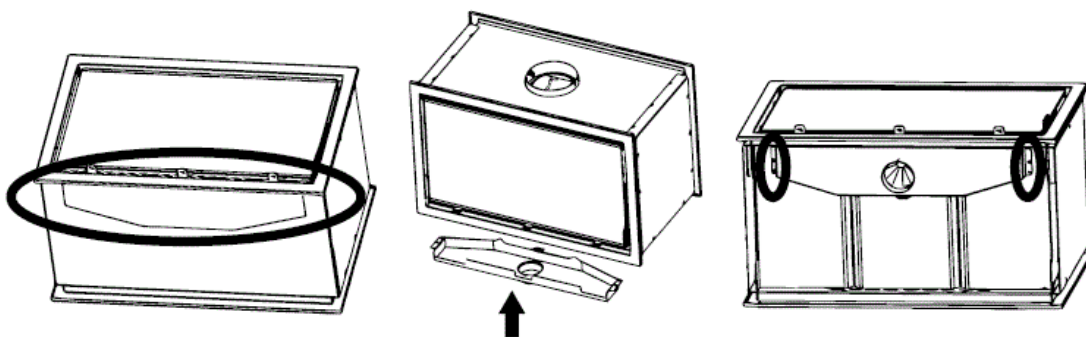

**Direct air kit for Octave 90i DS.** This optional kit enables you to bring the combustion air from the outside and will require the stove to be installed with a space underneath. This is best achieved by supporting the stove on masonry leaving space for the kit and ducting.

To install the kit remove the knock-out section under the stove and bolt the kit to the base using the bolts supplied. Then connect a duct with a minimum diameter of 100mm to the outside. Refer to *Firepower direct air guidance document*, details below.



Please also refer to our “Firepower Direct Air Guidance” document which can be found on the [www.firepower.co.uk](http://www.firepower.co.uk) website. This gives further consideration as well as mandatory duct sizing information if a direct air supply duct is being connected to the stove.

## ii. AirSmart



Connecting an AirSmart controller and vent is a way to avoid potential ventilation problems. A door sensor is fitted to the stove door and whenever the door is opened the controller opens a sealed vent to the room to supply extra fresh air. If there is a power cut then the vent is also opened as an additional safety feature. The AirSmart controller can be a stand-alone unit, or combined with a full automated stove

controller (as pictured) which also automatically regulates the burning rate of the stove, and adds in additional safety features.

## 7. The Chimney



All flue components used must be suitable for solid fuel fires, rated to T400°C, and comply with the relevant regulations regarding their construction and installation and all manufacturers' instructions must be followed. Calculation of the chimney design can be done according to EN 13384-1 and EN 13384-2 and/or with reference to Document J of the Building Regulations.

Particular attention must be made in regard to the distance to combustible materials.

If there is a chamber then it should be closed off above the stove with a concrete slab, lintels or fireproof stud work.

The following chimney designs are possible:

**Brick or block wall chimney:** This should be lined with pumice liners (not clay liners) of the correct diameter and the starter block should be set on the slab. The stove is then connected to the starter block with an adjustable length of single skin flue.

**Twin wall stainless steel insulated chimney:** The hole in the top of the chamber should be a good fit around the pipe using a fire stop plate.

**Stainless steel flexible liner (Class 1 - suitable for solid fuel, either 316 or 904 grade).** This is used to re-line an existing Class 1 masonry chimney: The liner should connect to the appliance via a length of rigid flue at least 500mm long. The liner should be firmly fixed to the chimney wall with a bottom support bracket or, if that isn't possible, then every pipe connection, including the connection to the stove, should be secured with at least two stainless steel self-tapping screws. The flexible liner should be insulated. The chimney should be fitted with a cowl or appropriate chimney pot to prevent rain entry.

Offsets used in the flue run can adversely affect the chimney's performance. Any bends used should be the minimum offset possible from the vertical (maximum permissible is 45°) and no more than four offsets should be used in any one system. If bends are used then it may be necessary to increase the height of the chimney to counteract any detrimental effect they may have on the chimney draught.

The chimney must be able to maintain a draught of 12 Pascals, with a tolerance of +/- 2 Pascals.

Flue termination heights must comply with the requirements of Document J of the Building Regulations.

Adequate provision must be made so that all internal parts of the chimney can be cleaned.

This stove is not suitable for use on a shared chimney.

## 8. Advice on fitting suitable alarms

At least one suitable and effective smoke alarm should be fitted in a suitable location. Alarms should be mounted on the ceiling at least 300mm from any walls and within 5 meters of the protected area. This may mean installing more than one alarm, and it is recommended to choose units that can be linked together. The smoke alarm should be capable of waking any occupants sleeping. The alarm should be tested with this in mind before the final fixing is made. The smoke alarm should be of the optical or photo electrical type since this is particularly sensitive to dense smoke such as produced from a smouldering fire. The smoke alarm should be fitted with an extra-long life battery and have a hush button to allow for temporary deactivation. This should be tested routinely.

A carbon monoxide alarm certified to BS EN 50291 should also be fitted and, on boats, it should be suitable for marine use.

## 9. Controlling the stove

The Octave models have three levers allowing you to control the primary, secondary and tertiary combustion air supply.

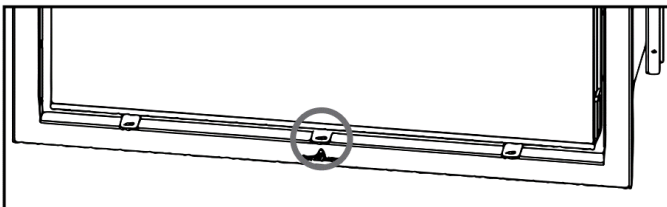

The **primary air** control lever is situated under the door in the middle. The amount of air entering the stove increases when the lever is moved in the direction of the large side of the triangular cut-out on the lever.

This should be open when lighting or re-fuelling and closed during normal running of the stove.

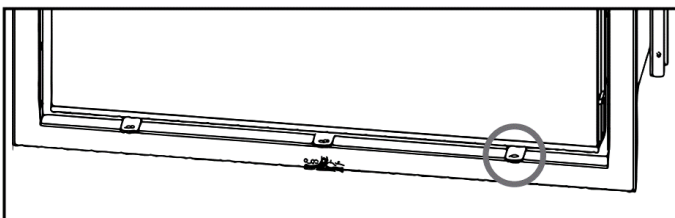

The **secondary air** control lever is situated under the door on the right hand side. The amount of air entering the stove increases when the lever is moved in the direction of the large side of the triangular cut-out on the lever.

This should be fully open during lighting but once the stove is hot it can be adjusted down in conjunction with the tertiary control to produce a steady and efficient burn with the best flame pattern.

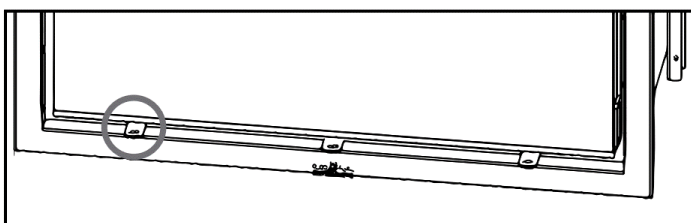

The **tertiary air** control lever is situated under the door on the left hand side. The amount of air entering the stove increases when the lever is moved in the direction of the large side of the triangular cut-out on the lever.

This should be fully open during lighting but once the stove is hot it can be adjusted down in conjunction with the secondary control to produce a steady and efficient burn with the best flame pattern.

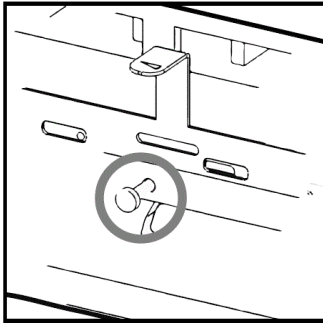

The Octave 90i and 90i DS have an **Adjustable flue baffle** that prevents over-drawing and gives the user greater control over the burning rate. This opens automatically when the door is opened. The position of the flue baffle when the door is closed can be adjusted with an adjustment screw positioned centrally above the firebox. Turn it to the right to increase the opening, to the left to reduce the opening. This allows the installer to 'tune' the stove according to whether the chimney has a strong or weaker draught.

## 10. General information about the working of the stove

Always use a glove

Do not use any flammable liquid fluids for lighting the fire. The door of the firebox should be opened only when adding fuel, apart from leaving the door slightly ajar during the lighting phase.

Use only suitable fuels.

Check that there is enough fresh air coming into the room. Stoves should only be used by adults. All parts of the appliance, especially the external surfaces will be hot to touch when in operation and due care will need to be taken. Make sure that children are never alone near the stove. Never leave the stove for a long period of time without surveillance.

The stove should be used only according to the instructions in this manual.

### ***Starting the stove***

Please pay attention to the minimum space between the stove and flammable objects when lighting a fire.

1. Primary secondary and tertiary controls should be fully open. |
2. Remove enough ash from the grate to let air through but leave some of the ash there. Put 2 larger logs as a base in the centre of the firebox, then some kindling on top, and finally 2-3 firelighters on top.
3. Light the firelighters and close the door.
4. After approximately 5 to 10 minutes, when the fire is burning fully, carefully open the door, put 1 to 2 pieces of the wood into the firebox, and then close the door.
5. When all the fuel is properly burning, and the working temperature of the stove is achieved (after approximately 20-30 minutes), gradually move the primary air regulator backwards, but ensure that there is still a visible flame.
6. When the stove is up to temperature and the fire burning well then the primary regulator can be completely closed.
7. The door should only be opened again when the fuel has burned right down and you want to put new fuel in. If there is insufficient burning material in the fire-bed to light a new fuel charge, excessive smoke emission can occur. Refuelling must be carried out onto a sufficient quantity of glowing embers and ash that the new fuel charge will ignite in a reasonable period. If there are too few embers in the

fire bed, add suitable kindling to prevent excessive smoke. It is recommended that the secondary air regulator is kept fully open in order for the “glass cleaning” to be most efficient, and to avoid the glass “fogging”.

8. Use the amount of fuel you place in the stove to regulate the room temperature. To burn at the nominal output, the stove requires refuelling every 45-50mins with approximately 2.5, 2.7, and 2.9kg of wood logs for the 70F, 70LS, 70B & 70i, 90i, and 90i DS respectively.

9. To achieve slow combustion, it is necessary to lay logs with one crossed over the other at 45°, the primary air control must be fully closed and the secondary and tertiary air controls adjusted to achieve a steady burn and a good flame pattern.,

10. When adding larger wood it is good practice to put in a couple of smaller bits first as the larger logs then light faster, so producing less smoke. When adding wood, the primary air control must always be open, and left open until the new logs have caught fire. At that point close the primary control and leave the secondary and tertiary air to facilitate the combustion.

THE STOVE SHOULD NEVER BE FILLED EXCESSIVELY. EXCESSIVE AMOUNTS OF WOOD OR AIR FOR COMBUSTION CAN CAUSE OVERHEATING AND DAMAGE THE STOVE.

During the first few times the stove is used, it is possible that it can produce a slight smell while the paint is curing. This will disappear after a short while. If the smell appears, open the windows of the room for ventilation.

#### ATTENTION

THE ASHPAN MUST BE TIGHTLY CLOSED FOR PROPER REGULATION OF THE PRIMARY AND SECONDARY AIR. If ash is allowed to build up behind the ashpan then it can prevent the ashpan sealing properly.

## **11. Cleaning and maintenance**

The stove can be cleaned only when it is cold.

Pay attention while cleaning your stove not to damage, scratch or break essential parts.

Cleaning the glass should be done when the stove is cold using a damp cloth or, for heavier deposits, a pad designed specifically for cleaning stove glass.

#### Attention

The stove paint only achieves its ultimate strength after reaching its rated temperature a few times.

To avoid damaging the paint, it is recommended to clean the stove surface only when the paint achieves its ultimate hardness.

It is important to have the chimney regularly checked and cleaned by a qualified chimney sweep.

The chimney can be swept through all the Octave models once the baffle plate has been removed. The Octave 90i and 90i DS can be swept through the appliance using suitable chimney sweeping equipment that will fit past the flue baffle, such as a drill driven sweeping set. Care must be taken not to disturb the flue baffle seating. All soot should be removed once the sweeping is completed. See Section 5 for how to re-seat the baffle plate.

## **12. In the case of chimney fire**

If the wrong or unseasoned wood is used, it is possible that a chimney fire can occur due to the accumulation of deposits inside the chimney.

Immediately close all air regulators on the stove and call the fire brigade.

If a chimney fire was to occur, an experienced professional should be employed to check the entire flue system.

## **13. Suitable materials for lighting**

The stove should be used for the combustion of natural wood and wood briquettes.

Some of the best wood for the stove is beech and birch. These types of wood have the highest burn temperature, and they burn the cleanest, as long as they have been stored in a dry place for a sufficient length of time.

If the glass window blackens excessively during burning it is usually an indication that the moisture content of the firewood is too high.

Do not use any of the following:

- Damp wood or treated wood
- Cardboard
- Bark or plywood
- Plastic or other waste

Fresh wood should be cut up and stored 12 to 18 months in open storage, but protected from rain. According to the manual, any wood used should have a maximum humidity of 20%.

## **14. Wood seasoning and storage**

In order to dry or "season" freshly cut firewood should be stored in a well-ventilated area protected from moisture for approximately 2-3 years. Store your wood split so that the release of moisture is quicker.

Do not stack the logs too tight to ensure the best possible air circulation. Firewood should not be stored directly on the ground. Do not store your firewood under tarpaulins, plastic sheeting or in poorly ventilated locations.

Firewood that is already seasoned or dry should be stored in a suitable dry location.



## 15. Reducing particulate emissions

Sustainably managed and sourced wood has significantly lower carbon emissions than oil or gas. On the other hand particulate emissions have a harmful effect on health, and there many ways in which you can reduce them:

- Only burn dry, well seasoned wood (with a moisture content of 20% or less measured on a 'wet basis', or 25% or less measured on a 'dry basis'). Look out for the WoodSure "Ready to Burn" logo.
- Light your stove using the "upside down method" where you start with a couple of bigger logs, then the kindling, then the firelighters. This gets the firebox up to temperature faster, and has been shown to result in lower particulate emissions in lab tests.
- Adjust the amount of wood you put into the fire based on how much heat you actually need. Do not fill the fire chamber up and then try to control the heat output by turning down the air controls.
- Make sure that the fire is burning well. Some signs of this are that the ash should be white. Black charcoal in the ash indicates an incomplete burn. The combustion chamber lining of the stove should be bright after firing and not sooty black. You should see good flames in the firebox at all times, without wisps of smoke. Incomplete combustion is generally always to do with an improper mix of three things: temperature, air, and fuel.
- Never "turn it down for the night".

Your stove must not be used to burn waste.

## 16. Emptying the ashpan

It is recommended to clean out the ash every day. Be careful that too much ash is not accumulated otherwise there is the danger that, if the ash reaches up to the grate, it will not cool sufficiently and may get damaged.

Before emptying the ashpan, check if there are any embers left in the ashtray.

Even though the ash is cold from the outside, it is possible that there are embers within the ash which can lead to a fire in the waste bin.

## 17. Malfunction and service

In the event of a product malfunction please contact your supplier. If the stove is under warranty your supplier will take care of the warranty claim. Regular maintenance of the stove and flue should be carried out by a competent engineer. Use only replacement parts as recommended by the manufacturer.

## 18. Troubleshooting

Symptom	Cause and Solution
The stove glass is black and sooty. The glass should be wiped clean every few days but if it is getting excessively black then there are a number of probably causes.	<ul style="list-style-type: none"><li>• The firewood is too wet. Only use wood with a moisture content of 20% or less.</li><li>• The firebox is being overloaded with too much wood. This will cause an excess of moisture in the firebox leading to blacking of the glass.</li><li>• Too little wood is being used from the start or the air lever has been closed down too quickly after the fire has been lit. This prevents the stove and chimney coming up to the proper working temperature and causes an incomplete combustion.</li><li>• The chimney has insufficient draw due to it being too short or terminating in the wrong place.</li><li>• The fire is receiving insufficient combustion air caused by a blockage or an undersized combustion air duct.</li></ul>
Fire is difficult to start	<ul style="list-style-type: none"><li>• The moisture content of the wood is too high. Only use wood with a moisture content of 20% or less.</li><li>• The logs are too thick. Kindling and thinner split logs should be used to start the fire. Bigger logs should only be used once the stove is hot.</li><li>• The fire is receiving insufficient air. Is the supply air control set correctly and are the combustion air ducts free of obstructions?</li><li>• Are the chimney and connectors free of obstructions?</li></ul>
When adding wood, smoke is spilled from the door opening.	<ul style="list-style-type: none"><li>• Is the wood dry enough?</li><li>• Has sufficient wood burnt to bring the stove and chimney to operating temperature?</li><li>• Is the chimney correctly sized?</li><li>• Is the chimney suffering from downdraft (i.e. puffing smoke during certain weather conditions). Check that the chimney terminates sufficiently far away from trees or nearby buildings. Fit an anti-downdraft cowl.</li><li>• Has the stove door been opened too fast?</li></ul>
Too fast burning / wood consumption too high	<ul style="list-style-type: none"><li>• Were adequately sized logs used?</li><li>• Has too much wood been loaded into the firebox</li><li>• Was the air supply control set correctly and the supply of combustion air reduced?</li></ul>
The combustion chamber lining is black	<ul style="list-style-type: none"><li>• Check the combustion chamber, the baffle deflectors and the chimney for blockages.</li><li>• The moisture content of the wood is too high. Only use wood with a moisture content of 20% or less.</li><li>• Check that the stove is receiving sufficient combustion air.</li></ul>

## 19. Commissioning checklist

### General Information

Stove purchased from.

\_\_\_\_\_

Tel: \_\_\_\_\_

Email: \_\_\_\_\_

Installed by.

\_\_\_\_\_

Tel: \_\_\_\_\_

Email: \_\_\_\_\_

Installation date.

0

Notice plate and accompanying checklist completed.

Notice plate location.

0

Confirm that relevant local and national regulations have been followed, including, in the UK, Document J of the Building regulations.

### Handover

Handover: user shown how to use the appliance and has the necessary documentation.

Handover: the importance of using only well seasoned wood has been explained.

Handover: safety issues and required maintenance explained to the user.

### Signed

Commissioning engineer's signature\*

\_\_\_\_\_

*\*By signing this you confirm that all commissioning checks above have passed, and that operation and maintenance of the appliance have been explained to the customer in full in line with this user manual.*

## 20. Warranty

The warranty cover is effective from when the unit is handed over to the buyer.

In case the commissioning does not take place within 3 months from the date of purchase then the warranty period starts on the day of purchase of the product, which must be demonstrated by proof of purchase such as a sales receipt or paid invoice from the seller.

All liability for any accidents due to failure to observe the specifications contained in the use and maintenance manual accompanying the device is declined. Furthermore all liability deriving from improper use of the product by the user (including heat-shock, overload or misuse of the firebox), unauthorised modifications and/or repairs, and the use of non-original spare parts or spare parts not designed for use on this product model are also declined.

The duration of warranty is three years on the body of the stove and moving parts (hinges, handle, and fittings).

Please note that the warranty does not cover glues, seals, ceramic glass, the grate, and firebricks.

The warranty period and the scope of the warranty are granted under these terms and conditions beyond the statutory warranty, which remains unaffected.

The guarantee is not valid if there has been:

- Non-compliance with the assembly and operating instructions or there have been technical modifications to the stove by non-company personnel
- Improper handling, improper use, incorrect installation or incorrect connection of the stove to the heating system
- The stove has been lit when not connected to a heating system
- Missing or faulty maintenance to the stove or chimney
- Improper transport or improper storage
- Overheating, thermal overload and resulting deformation or discolouration of the stove or the viewing window
- Normal wear and tear of the stove.

Regardless of the statutory warranty, which has priority over the warranty within the statutory warranty periods, any defective parts that are demonstrably based on a material defect or manufacturer's defect are replaced free of charge within the scope of the stated warranty conditions.

Opus reserves the right to either eliminate the defect or replace the appliance. The warranty covers supplying a replacement part but does not cover any labour associated with fitting the part or any further damages or costs related to the defect nor costs arising from de-installation or re-installation of the appliance.

If parts are replaced then the warranty period will be extended for the replaced part. Only spare parts approved by Opus may be used.

## 21. Dimensions and parts

### i. 70F, 70LS, 70B

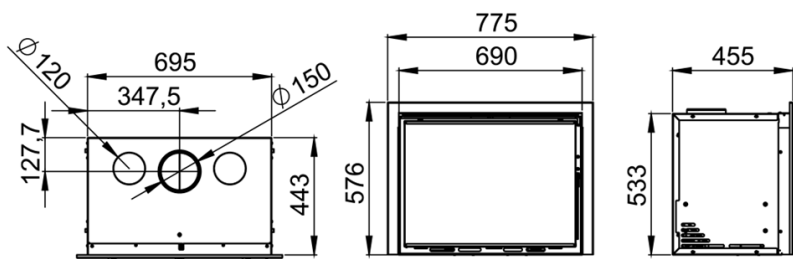
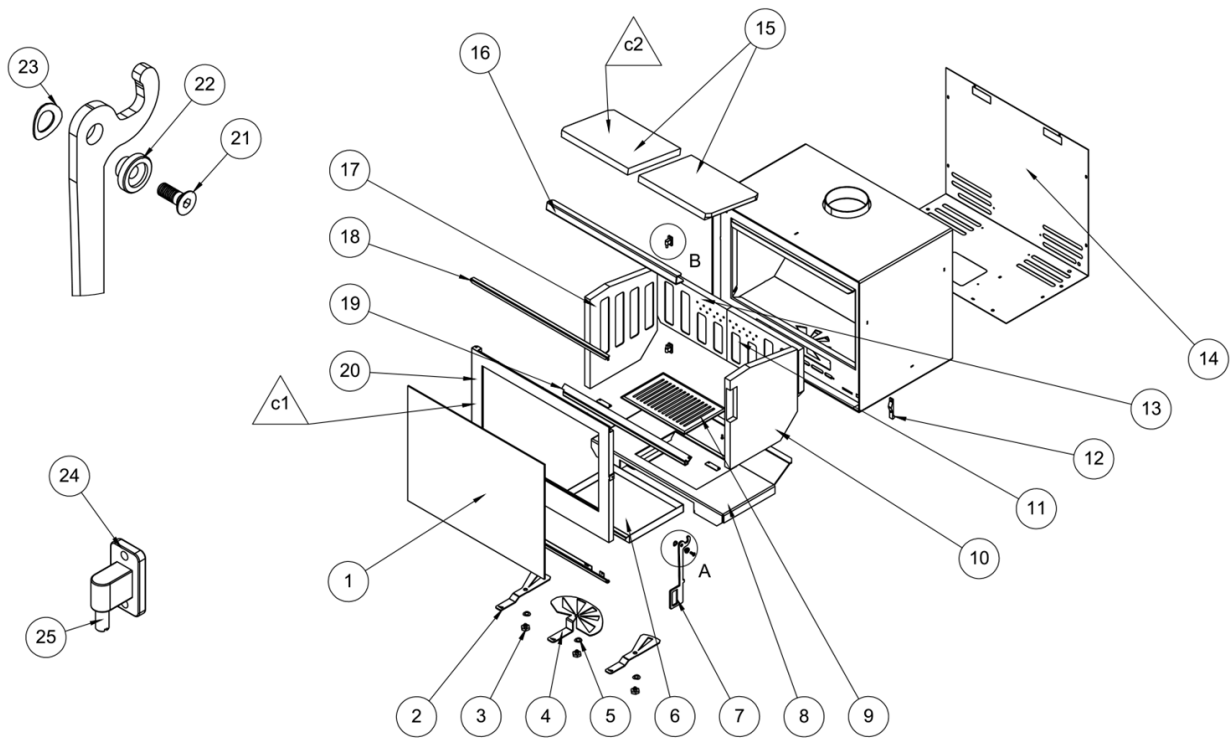

1	Glass	15	Baffle plate vermiculite
2	Dc regulation	16	Baffle plate support
3	Primary support	17	Left side vermiculite
4	Primary regulation	18	Glass support
5	Spring washer $\varnothing$ 13	19	Logs retainer
6	Ash pan	20	Door
7	Handle	21	Handle screw
8	Grille	22	Shell for handle
9	Cast iron grille	23	Spring washer $\varnothing$ 10,5
10	Right side vermiculite	24	Hinge
11	Right rear vermiculite	25	Hinge pin
12	Tightening plate	c1	Complete door (no glass)
13	Left Rear vermiculite	c2	Complete baffle
14	Air chamber		

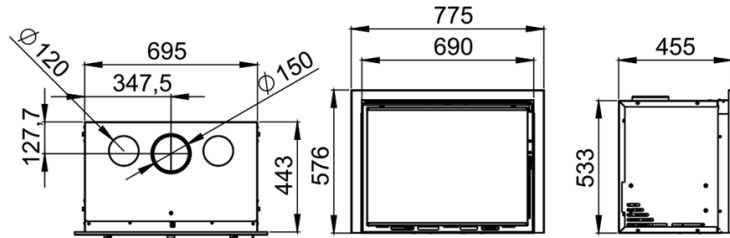
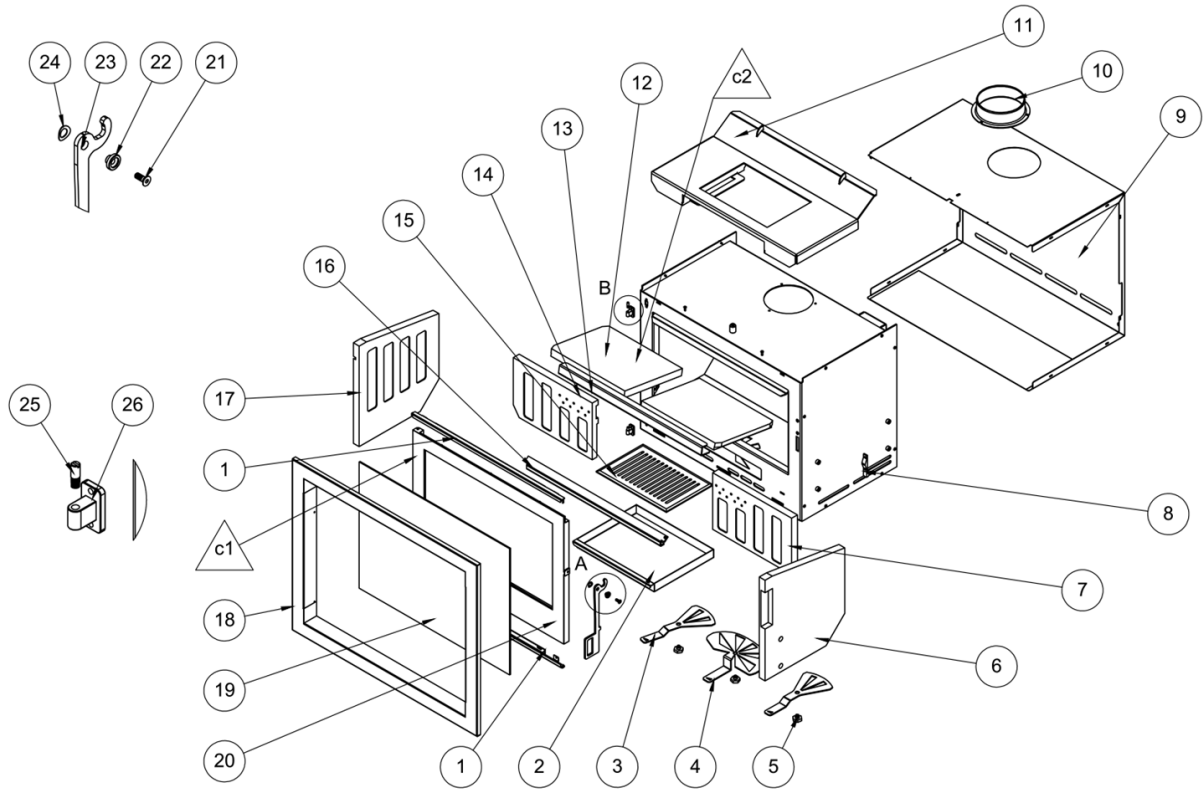

1	Glass support	15	Cast iron grille
2	Ash pan	16	Log retainer
3	Dc regulation	17	Left vermiculite
4	Primary regulation	18	Frame
5	Primary support	19	Glass
6	Right vermiculite	20	Door
7	Right rear vermiculite	21	Handle screw
8	Tightening plate	22	Shell for handle
9	Air chamber	23	Handle
10	Smoke outlet	24	Spring washer $\varnothing$ 10,5
11	Base grille	25	Hinge pin
12	Baffle plate vermiculite	26	Hinge
13	Baffle plate support	C1	Complete door (no glass)
14	Left Rear vermiculite	C2	Complete Baffle plate

goi

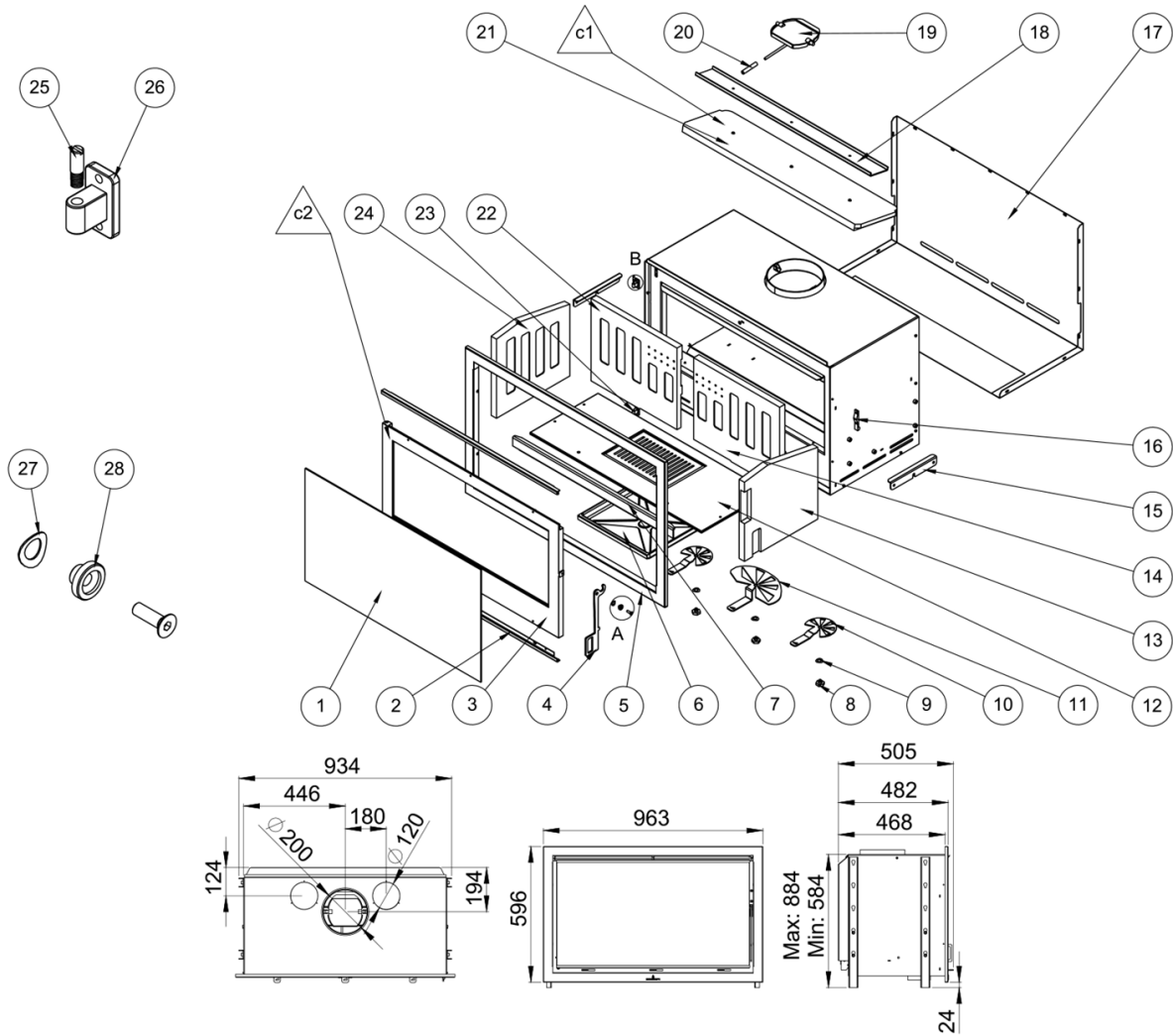

1	Vision glass	16	Tightening plate
2	Glass support	17	Rear chamber
3	Door	18	Baffle plate reinforcement
4	Handle	19	Draught control valve
5	Frame	20	Adjustment screw for cut-offs
6	Ash pan	21	Baffle plate vermiculite
7	Logs retainer	22	Left rear vermiculite
8	Primary support	23	Lower hinge
9	Spring washer $\varnothing 13$	24	Left side vermiculite
10	Dc regulation	25	Srew hinge
11	Primary regulation	26	Hinge
12	Grill	27	Spring washer $\varnothing 10,5$
13	Right side vermiculite	28	Shell for handle
14	Right rear vermiculite	C1	Complete baffle
15	Vermiculite support	C2	Complete door (without glass)

goiDS

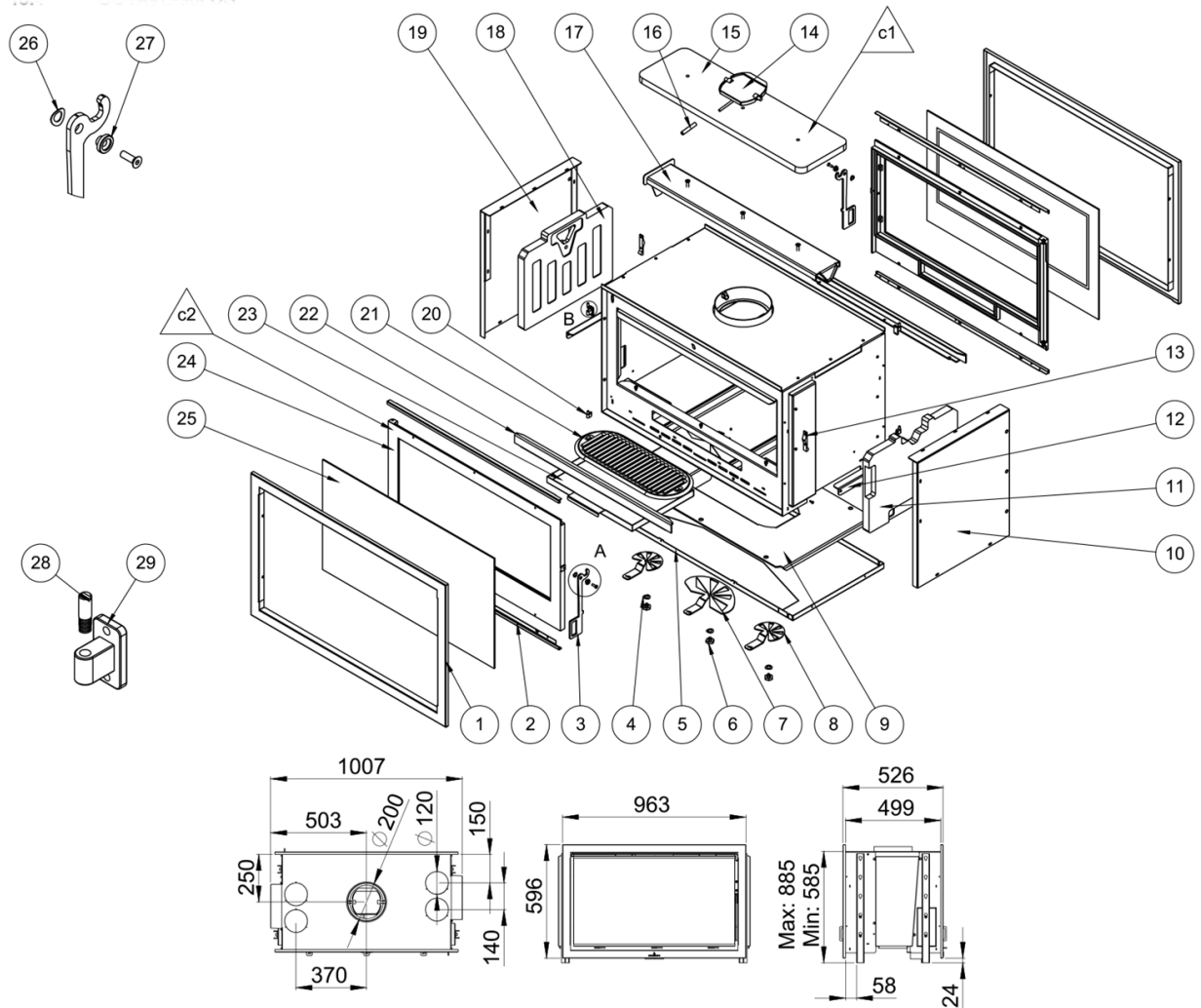

1	Frame	16	Adjustment screw for cut-offs
2	Glass support	17	Double combustion pipe
3	Handle	18	Left side vermiculite
4	Spring washer $\varnothing 13$	19	Left chamber
5	Lower chamber	20	Lower hinge
6	Primary support	21	Grille
7	Primary regulation	22	Logs retainer
8	Secondary regulation	23	Ash pan
9	Base grille	24	Door
10	Right chamber	25	Vision glass
11	Right side vermiculite	26	Shell for handle
12	Vermiculite support	27	Spring washer $\varnothing 10,5$
13	Tightening plate	28	Screw hinge
14	Draught control valve	29	Hinge
15	Baffle plate vermiculite		





Distributed by Firepower  
Dunkeswell Business Park,  
Dunkeswell, Devon  
EX14 4RD, UK

[www.firepower.co.uk](http://www.firepower.co.uk)

+44(0) 800 246 1260